

ANCILLARY EQUIPMENT

Telephone Line Manager STC 105C



- **Verifies Telephone Line Integrity**
- **D.P.D.T. Relay Output**
- **Dual Line Switching Capability**
- **N.O. or N.C. Alarm Panel Output**
- **Voltage and Current Monitoring**
- **Selectable Delay**
- **Microprocessor Controlled**

Description of device and operation

The **STC Model 105** Telephone Line Manager is a powered ancillary device for monitoring telephone line voltage. The device is completely isolated electrically from the monitored line by optical coupling. It repetitively interrogates the telephone voltage to determine if the voltage exceeds the preset minimum threshold. When the voltage falls below this minimum for more than the selected delay interval, the D.P.D.T. relay switches, the alarm output contacts change state, and the alarm LED lights. When any "in house" device (such as a fax, alarm panel, or computer modem) is using the telephone line, the **STC 105** current monitoring circuit decreases the threshold for an alarm condition to virtually eliminate false alarms created by normal telephone equipment operation. An alarm condition will auto-restore 5 seconds after the line voltage returns to normal. The relay output can be used to directly select a second line or backup communications link, operate audible devices, trip zones on the alarm panel, or enable an "audible on line fault". The alarm output is an opto-coupled N.O. or N.C. dry contact (selectable) designed to directly interface with the alarm panel zones. The 12 V.D.C. power needed to operate the Line Manager is derived from the auxiliary power output normally available from the control. The compression terminals are convenient to use and the double-sided foam tape mounting makes installation quick and easy. An earth ground terminal is supplied to support the lightning and spike protection circuits.

Specifications

ELECTRICAL

Min. Telephone Line Voltage:

2.8 no load, .5 off hook (At house phone terminals)

Supply Voltage:

10-15 VDC, reverse polarity protected

Supply Current:

30 ma. average quiescent, 90 ma. in alarm

Input Impedance:

10 Megohm minimum

Line Isolation:

Opto-isolator, 5000 V. peak standoff, 50 Megohm, telephone line to power supply

Alarm Output:

Opto-isolator dry contact, selectable N.C. or N.O., auto-restoring, 20 milliamp continuous load

Switching Output:

D.P.D.T. relay, dry contacts, 2 amp. auto-restoring

Time Delay:

Selectable 10, 30, 120 seconds, line fail to alarm condition (+/- 1% microprocessor controlled)

Time to Restore:

5 seconds

Displays:

Light Emitting Diodes, Alarm and Line Check

MECHANICAL

Size:

1.75" wide X 4.00" long X 0.80" high (including mounting pads and terminal blocks)

Weight:

2 oz. (Shipping weight: 6 oz.)

Terminals:

Compression Type, Euro style barrier block

Mounting:

Double sided foam tape (supplied)

GENERAL

Warranty:

Two years parts and labor. (See separate warranty statement for complete details.)

Ordering Information

STC 105C Telephone Line Manager

Installation Instructions for STC 105C Telephone Line Manager

1. Mount the 105 PC board using the attached foam tape if the terminal blocks can be reached for wiring after mounting the Manager. If the PC board cannot be wired after being installed, skip the mounting and proceed with the wiring in step 2. and mount the unit after completing the wiring.
2. **DETERMINE WHICH OF THE FOLLOWING SITUATIONS APPLY TO THIS INSTALLATION:**
 - A. Monitor the telephone line with an alarm output to the panel on telephone line failure. (see Figure 1)
 - B. Monitor the telephone line, provide an alarm output to the panel, and enable an audible device or sounder during the failure. (see Figure 1)
 - C. Monitor the primary telephone line, provide an alarm output and switch to the alternate phone line or cellular backup for the duration of the primary line failure. (see Figure 2)
3. Connect the telephone line(s) and other devices as shown in the appropriate figure below.
4. Connect 12 VDC from the panel "AUX PWR" or from a regulated 12 VDC source as shown in figure 1 or 2 below.
5. Test by disconnecting the "TELCO IN" wires. An alarm condition will occur after a delay of the selected time interval.
6. Reconnect the telephone line and verify that the alarm condition clears and correct signals were received by the Central Station.

For Situation A or B, Wire and set jumpers as instructed in Figure 1 below.

Figure 1.

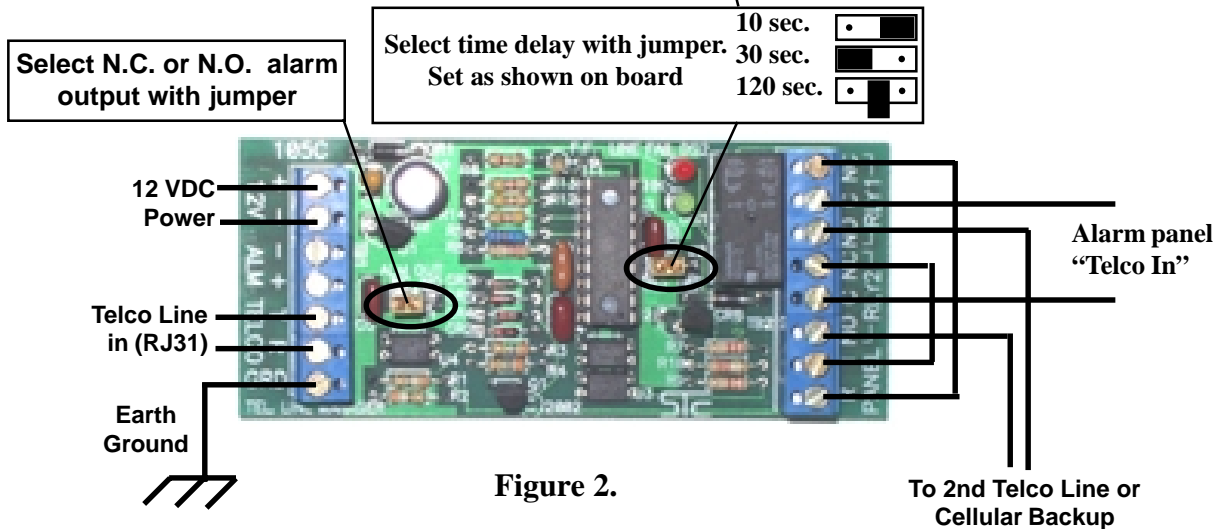
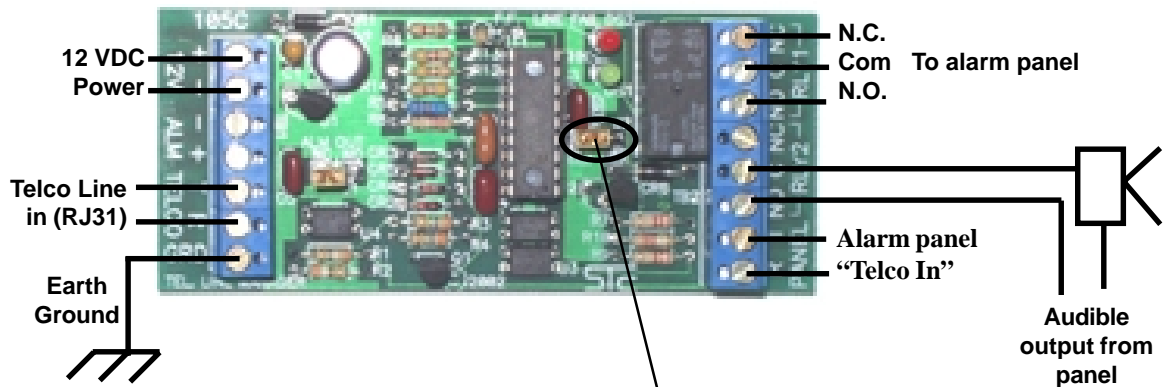

Figure 2.

For Situation C, wire and set jumpers as instructed in Figure 2. above